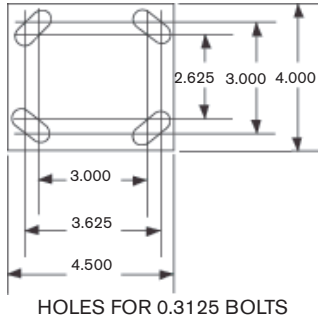

## 31-SL 400 SERIES

## INSTALLATION

NO. 31 TOP PLATE  
(STANDARD ON 400 SERIES)

## FEATURES

- Oil impregnated permanently lubricated sintered bearings for all moving parts
- Sealed precision ball bearings in the wheel permanently lubricated for long life and low rolling resistance
- Sealed swivel assembly with grease fitting for ease of access
- Load rating 1000 pounds at maximum spring deflection
- Various mounting plates available

Available in 3", 4", 5", 6", and 8" models



31-SL404-PSE

WHEEL DIAMETER	TREAD WIDTH	LOAD CAP./LBS	BEARING TYPE	MODEL NUMBER	SWIVEL RADIUS	OVERALL HEIGHT NO LOAD	OVERALL HEIGHT MAX. LOAD
<b>SOLID ELASTOMER</b>							
3"	2"	900	PRECISION BALL	31-SL403-PSE	3.50"	7.00"	6.00"
4"	2"	900	PRECISION BALL	31-SL404-PSE	4.00"	7.50"	6.50"
5"	2"	1000	PRECISION BALL	31-SL405-PSE	4.85"	9.00"	8.00"
6"	2"	1000	PRECISION BALL	31-SL406-PSE	5.30"	9.50"	8.50"
8"	2"	800	PRECISION BALL	31-SL408-PSE	7.30"	11.50"	10.00"
<b>NEOPRENE</b>							
4"	2"	450	PRECISION BALL	31-SL404-PD	4.00"	7.50"	6.50"
5"	2"	500	PRECISION BALL	31-SL405-PD	4.85"	9.00"	8.00"
6"	2"	550	PRECISION BALL	31-SL406-PD	5.30"	9.50"	8.50"
8"	2"	550	PRECISION BALL	31-SL408-PD	7.30"	11.50"	10.00"

## INSTALLATION

## NO. 6 TOP PLATE

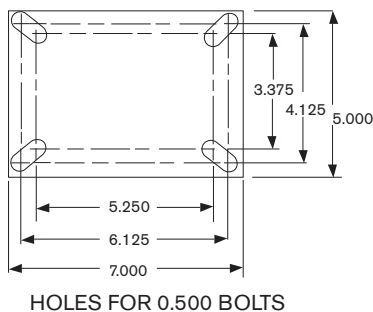

## 6-SL 900 SERIES

## FEATURES

- Oil impregnated permanently lubricated sintered bearings for all moving parts
- Tapered bearings in swivel
- Load rating to 2500 lbs
- Available in 5", 8", and 10" models
- Can be manufactured in additional sizes as required

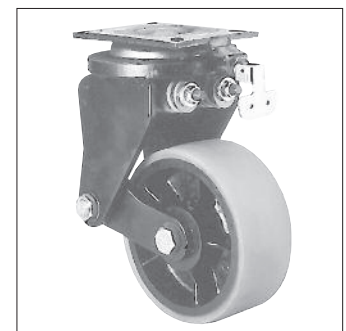

6-SL908-YU

WHEEL DIAMETER	TREAD WIDTH	LOAD CAP./LBS	BEARING TYPE	MODEL NUMBER	SWIVEL RADIUS	OVERALL HEIGHT NO LOAD	OVERALL HEIGHT MAX. LOAD
5"	2-1/2"	1000	PRECISION BALL	6-SL905-PSE	4.50"	10.00"	7.25"
8"	3"	2500	TAPERED	6-SL908-YU	6.90"	13.00"	12.00"
10"	3"	2500	TAPERED	6-SL910-YU	8.60"	15.00"	14.00"

# SPRING LOADED CASTERS

## SL 8510-YU



SL-8510-YU

### FEATURES

- Oil impregnated bearings in all pivoting points
- Grease fitting in swivel and wheel
- Sealed bearings in wheel
- Tapered bearings in swivel head and wheel
- Four position swivel locks and brakes available

### INSTALLATION

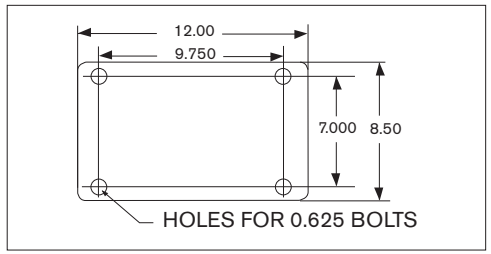

WHEEL DIAMETER	TREAD WIDTH	LOAD CAP./LBS	BEARING TYPE	MODEL NUMBER	SWIVEL RADIUS	OVERALL HEIGHT NO LOAD	OVERALL HEIGHT MAX. LOAD
10"	5"	10,000	TAPERED	SL8510-YU	9.40"	15.625"	14.50"

## TWIN WHEEL

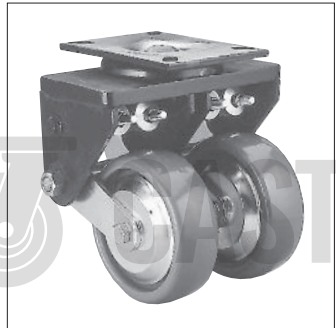

6-TSL2406-PSE

### FEATURES

- Twin wheels reduced resistance to swiveling
- Twin wheels spread load over a wider area
- Twin wheels offer higher load carrying capacity
- Available with swivel locks

### INSTALLATION

No. 6 and 5200 top plates

WHEEL DIAMETER	TREAD WIDTH	LOAD CAP./LBS	BEARING TYPE	MODEL NUMBER	SWIVEL RADIUS	OVERALL HEIGHT NO LOAD	OVERALL HEIGHT MAX. LOAD
6"	2"	2200	PRECISION BALL	6-TSL2406-PSE	6.35"	9.45"	8.45"

## GATE CASTERS



QSL-22-XD

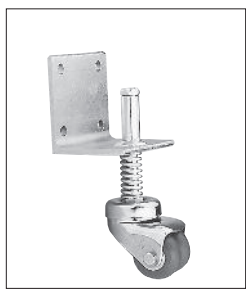

QSL-32-XD

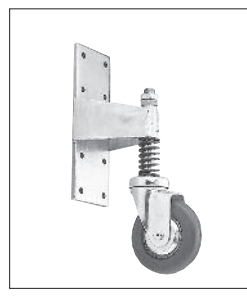

QSL-75-XD

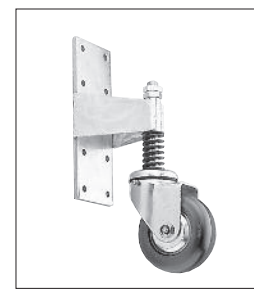

QSL-405-TD

WHEEL DIAMETER	CASTER MODEL NO.	OVERALL HEIGHT NO LOAD	OVERALL HEIGHT MAX. LOAD	SWIVEL OFFSET C/W BRACKET	LOAD CAPACITY
2"	QSL-22-XD	7.375"	6.375"	1.750"	18 lbs.
2"	QSL-32-XD	8.500"	7.625"	3.500"	200 lbs.
5"	QSL-75-XD	13.250"	12.000"	5.375"	300 lbs.
5"	QSL-405-TD	13.250"	12.000"	5.375"	400 lbs.