

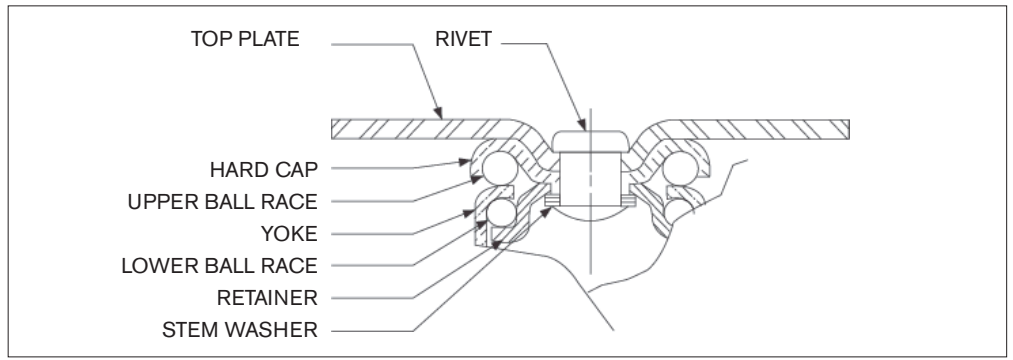

16-65-XD

FEATURES



- 3/8" Axle
- 1/2" Rivet
- Double row ball bearing swivel. Both raceways equal diameter
- Bright zinc finish
- All swivel parts case hardened to Rockwell 62C
- Thread guards standard on wheels



16-65R-XD

OPTIONS

- Brakes available, 3", 3.5", 4", and 5" models. Add letter "B".
- Four position swivel locks. Add letter "F". Not available on stem casters.
- Brakes and swivel locks cannot be combined on the same caster.
- Swivel seals with zerk in swivel and axle. Add letter "S".
- Zerk in axle only. Add letter "G".

INSTALLATIONS



16-65B-XSR

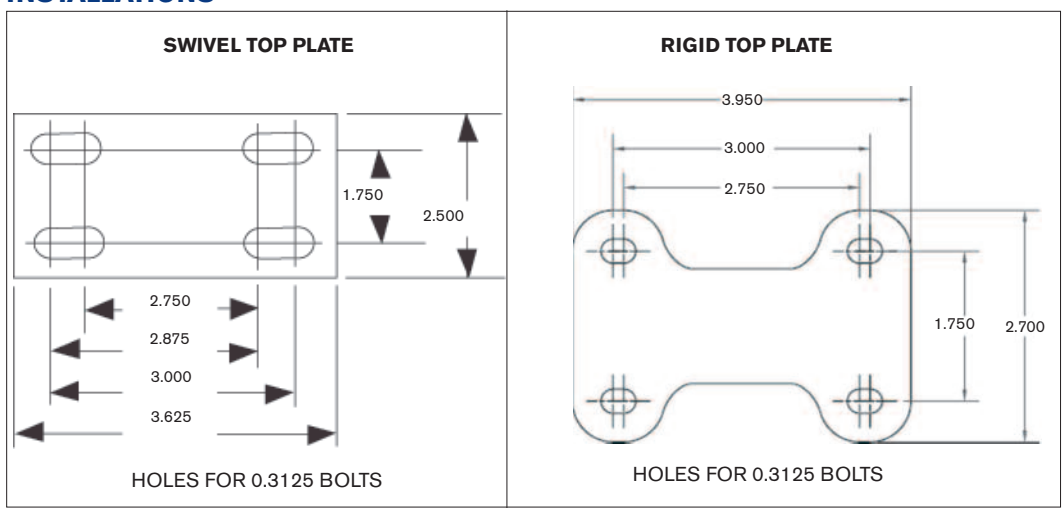

**NO. 16 TOP PLATE (STANDARD ON 60 SERIES)**  
 OPTIONAL TOP PLATES AND STEMS AVAILABLE

| WHEEL DIAMETER               | TREAD WIDTH | LOAD CAP./LBS | BEARING TYPE | SWIVEL MODEL | RIGID MODEL  | SWIVEL RADIUS | OVERALL HEIGHT |
|------------------------------|-------------|---------------|--------------|--------------|--------------|---------------|----------------|
| <b>NEOPRENE</b>              |             |               |              |              |              |               |                |
| 3"                           | 1-3/8"      | 200           | BALL         | 16-63-XD     | 16-63R-XD    | 2-3/4"        | 4-5/16"        |
| 3-1/2"                       | 1-3/8"      | 200           | BALL         | 16-63.5-XD   | 16-63.5R-XD  | 3"            | 4-3/4"         |
| 4"                           | 1-3/8"      | 225           | BALL         | 16-64-XD     | 16-64R-XD    | 3-1/4"        | 5-5/16"        |
| 5"                           | 1-3/8"      | 250           | BALL         | 16-65-XD     | 16-65R-XD    | 4"            | 6-5/16"        |
| <b>NEOPRENE - SUPER ROLL</b> |             |               |              |              |              |               |                |
| 2-1/2"                       | 1-3/8"      | 200           | BALL         | 16-62.5-XSR  | 16-62.5R-XSR | 2-1/2"        | 3-13/16"       |
| 3-1/2"                       | 1-3/8"      | 225           | BALL         | 16-63.5-XSR  | 16-63.5R-XSR | 3"            | 4-3/4"         |
| 4"                           | 1-3/8"      | 275           | BALL         | 16-64-XSR    | 16-64R-XSR   | 3-1/4"        | 5-5/16"        |
| 5"                           | 1-3/8"      | 325           | BALL         | 16-65-XSR    | 16-65R-XSR   | 4"            | 6-5/16"        |
| <b>SOLID ELASTOMER</b>       |             |               |              |              |              |               |                |
| 2-1/2"                       | 1-1/4"      | 300           | BALL         | 16-62.5-XSE  | 16-62.5R-XSE | 2-1/2"        | 3-13/16"       |
| 3-1/2"                       | 1-1/4"      | 350           | BALL         | 16-63.5-XSE  | 16-63.5R-XSE | 3"            | 4-3/4"         |
| <b>SEMI-STEEL</b>            |             |               |              |              |              |               |                |
| 2-1/2"                       | 1-1/4"      | 400           | SLEEVE       | 16-62.5-CI   | 16-62.5R-CI  | 2-1/2"        | 3-13/16"       |
| 3"                           | 1-3/8"      | 400           | SLEEVE       | 16-63-CI     | 16-63R-CI    | 2-3/4"        | 4-5/16"        |
| 3-1/2"                       | 1-1/4"      | 400           | SLEEVE       | 16-63.5-CI   | 16-63.5R-CI  | 3"            | 4-3/4"         |
| 4"                           | 1-3/8"      | 400           | SLEEVE       | 16-64-CI     | 16-64R-CI    | 3-1/4"        | 5-5/16"        |
| 5"                           | 1-3/8"      | 400           | SLEEVE       | 16-65-CI     | 16-65R-CI    | 4"            | 6-5/16"        |
| <b>V-GROOVED</b>             |             |               |              |              |              |               |                |
| 3"                           | 1-1/4"      | 300           | SLEEVE       | 16-63-CV     | 16-63R-CV    | 2-3/4"        | 4-5/16"        |
| <b>HARD RUBBER</b>           |             |               |              |              |              |               |                |
| 3"                           | 1-3/8"      | 350           | SLEEVE       | 16-63-H      | 16-63R-H     | 2-3/4"        | 4-5/16"        |
| 3-1/2"                       | 1-3/8"      | 375           | SLEEVE       | 16-63.5-H    | 16-63.5R-H   | 3"            | 4-3/4"         |
| 4"                           | 1-3/8"      | 400           | SLEEVE       | 16-64-H      | 16-64R-H     | 3-1/4"        | 5-5/16"        |
| 5"                           | 1-3/8"      | 400           | SLEEVE       | 16-65-H      | 16-65R-H     | 4"            | 6-5/16"        |

SLEEVE - M - BEARINGS AVAILABLE FOR WET APPLICATIONS.