

FEATURES

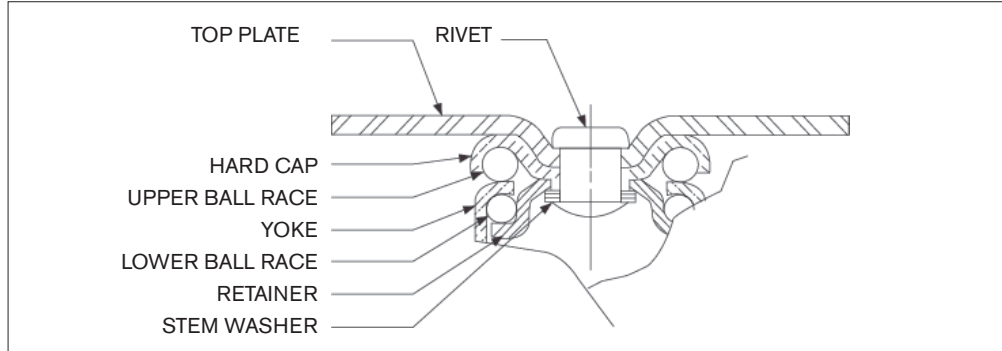

12-24-XD



- 5/16" Axle
- 7/16" Rivet
- Double row ball bearing swivel. Both raceways equal diameter.
- Bright zinc finish
- All swivel parts case hardened to Rockwell 62C
- Thread guards standard on sizes larger than 2"



12-24R-XD

OPTIONS

- Brakes available on 3", 4" and 5" models. Add letter "B".

INSTALLATIONS



12-24B-XD

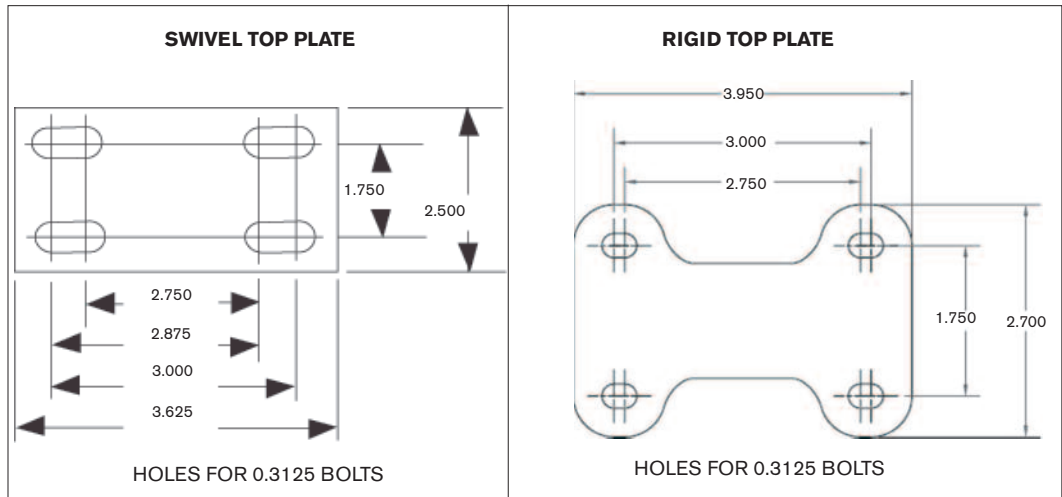

NO. 12 TOP PLATE (STANDARD ON 20 SERIES)

OPTIONAL TOP PLATES AND STEMS AVAILABLE

| WHEEL DIAMETER | TREAD WIDTH | LOAD CAP./LBS | BEARING TYPE | SWIVEL MODEL | RIGID MODEL | SWIVEL RADIUS | OVERALL HEIGHT |
|----------------------------|-------------|---------------|--------------|--------------|--------------|---------------|----------------|
| NEOPRENE | | | | | | | |
| 2" | 1" | 125 | BALL | 12-22-XD | 12-22R-XD | 2" | 3-1/8" |
| 2" | 1" | 75 | SLEEVE | 12-22-D | 12-22R-D | 2" | 3-1/8" |
| 3" | 1" | 125 | BALL | 12-23-XD | 12-23R-XD | 3" | 4-1/4" |
| 3" | 1" | 75 | SLEEVE | 12-23-D | 12-23R-D | 3" | 4-1/4" |
| 4" | 1" | 125 | BALL | 12-24-XD | 12-24R-XD | 3-3/8" | 5-1/4" |
| 4" | 1" | 75 | SLEEVE | 12-24-D | 12-24R-D | 3-3/16" | 5-1/4" |
| 5" | 1" | 125 | BALL | 12-25-XD | 12-25R-XD | 3-7/8" | 6-1/4" |
| 5" | 1" | 75 | SLEEVE | 12-25-D | 12-25R-D | 3-7/8" | 6-1/4" |
| NEOPRENE SUPER ROLL | | | | | | | |
| 2-1/2" | 1" | 125 | BALL | 12-22.5-XSR | 12-22.5R-XSR | 2-1/8" | 3-5/8" |
| 2-1/2" | 1" | 75 | SLEEVE | 12-22.5-SR | 12-22.5R-SR | 2-1/8" | 3-5/8" |
| SEMI-STEEL | | | | | | | |
| 2" | 1" | 100 | SLEEVE | 12-22-CI | 12-22R-CI | 2" | 3-1/8" |
| 2-1/2" | 1" | 125 | SLEEVE | 12-22.5-CI | 12-22.5R-CI | 2-1/8" | 3-5/8" |
| HARD RUBBER | | | | | | | |
| 2" | 1" | 100 | BALL | 12-22-XH | 12-22R-XH | 2" | 3-1/8" |
| 2" | 1" | 100 | SLEEVE | 12-22-H | 12-22R-H | 2" | 3-1/8" |
| 2-1/2" | 1" | 125 | SLEEVE | 12-22.5-H | 12-22.5R-H | 2-1/8" | 3-5/8" |
| 3" | 1" | 125 | SLEEVE | 12-23-H | 12-23R-H | 3" | 4-1/4" |
| 4" | 1" | 125 | SLEEVE | 12-24-H | 12-24R-H | 3-3/8" | 5-1/4" |